

Alana 3 Drawer Chest

Assembly Instruction



Packaging and instructions
printed on recycled materials

**Save the instructions for future reference.
Assembly of this furniture is best undertaken by two people.**

SJC brands

SJC Brands Pty Ltd abn. 58 106 988 578
4-6 Merryvale Rd, Minto, NSW 2566
t. 02 9603 5000 f. 02 9603 7000

e.customer.service@sjcbrands.com.au
p.o. box 5878 MINTO DC, NSW 2566
www.tasmaneco.com.au

Hardware List

Camlock x 36



Locking pin X 36

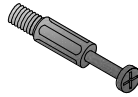

M6 x 35 Bolt x 4



Allan key x 1



Wall strap x 1



M4 x 25mm Self-tapping Screw x 2



Warning

Small parts can present choking hazard. Always keep small parts out of reach of children both during and after assembly. Store any spare or unused parts in a safe place.

Assembly tips for hardware

We recommend tightening all screws and connectors by hand. If using a cordless driver, set the speed to a slow setting and the clutch to a low setting to prevent excessive tightening that may result in damage to your furniture.

Screws



Recheck tightness

Re-tighten all connector bolts (at least two months after assembling the cot), as some connectors may loosen as the cot settles. Periodically check all of the connector screws, making sure they are tight.

Parts checklist

Side panel x 2

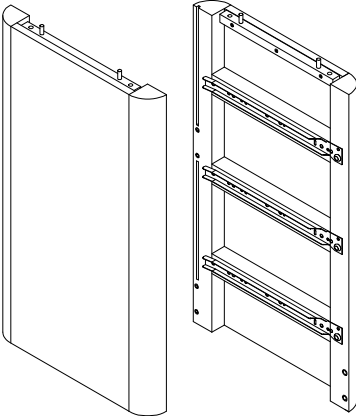

Top board x 1

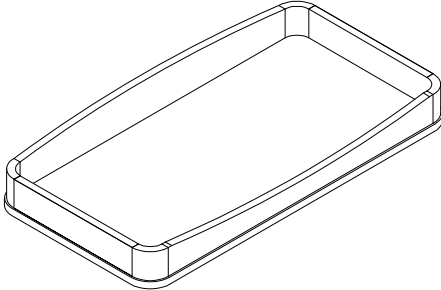

Front bottom rail x 1

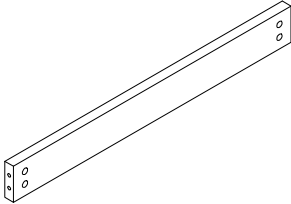

Back bottom rail x 1

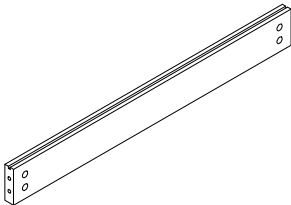

Back middle rail x 1

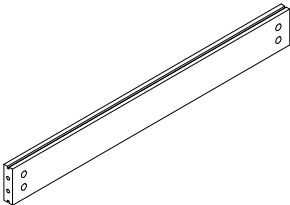

Back panel x 2

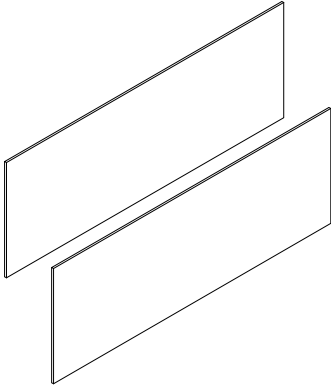

Drawer side panel (right) x 3

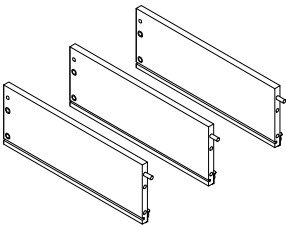

Drawer side panel (left) x 3

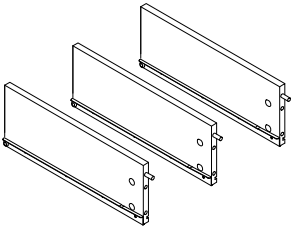

Drawer back panel x 3

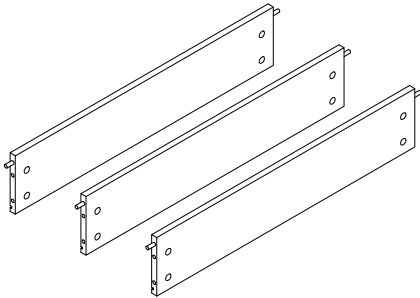

Drawer front panel x 3

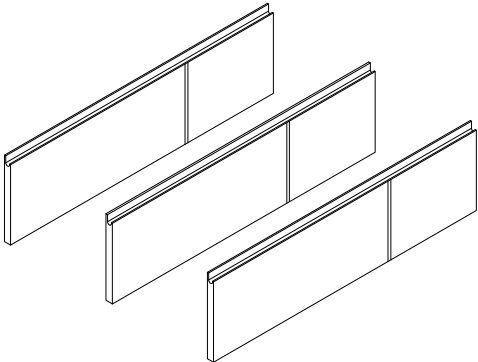

Drawer base panel x 3

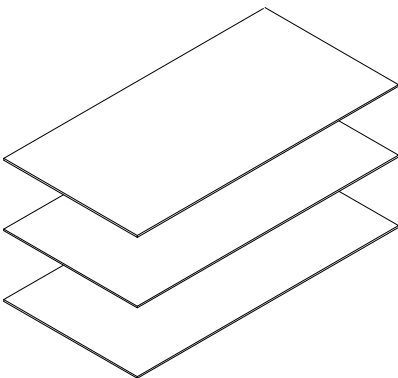

1 Fit locking pins to side panel.

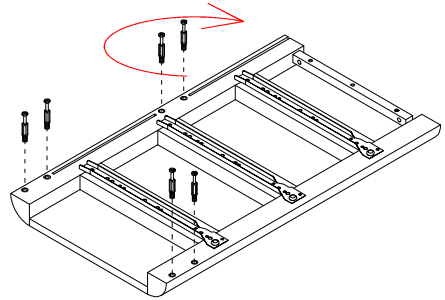
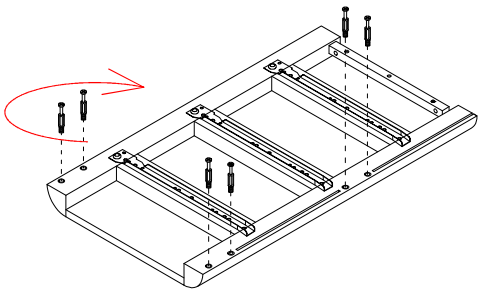
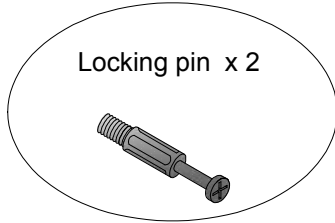

2 Fit front bottom rail, back middle rail, back bottom rail to one side panel secure with camlocks.

3 Insert back panel sliding into groves on back middle rail and back bottom rail.

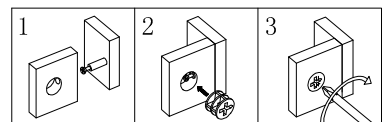
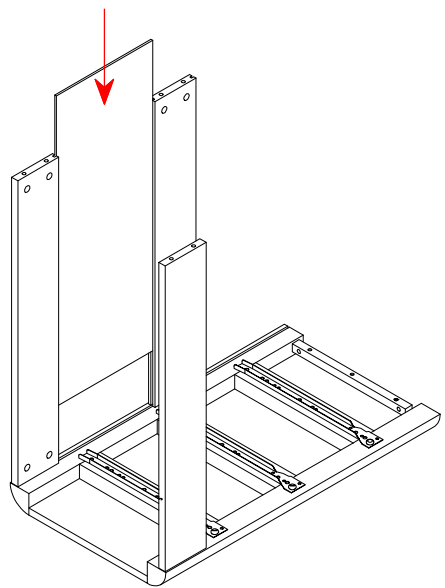
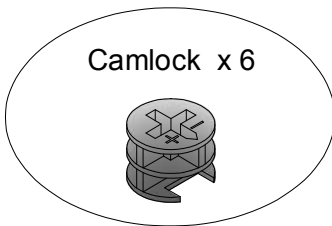
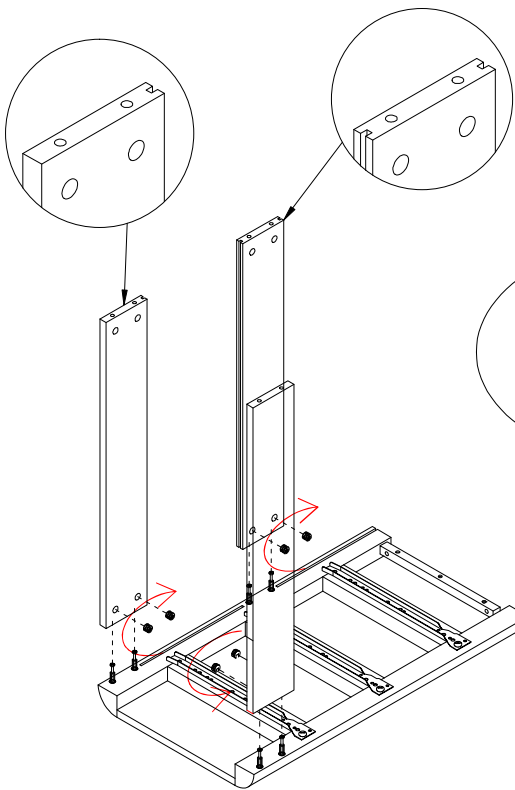

4 Fit other side panel to rails secure with locking pins and camlocks.

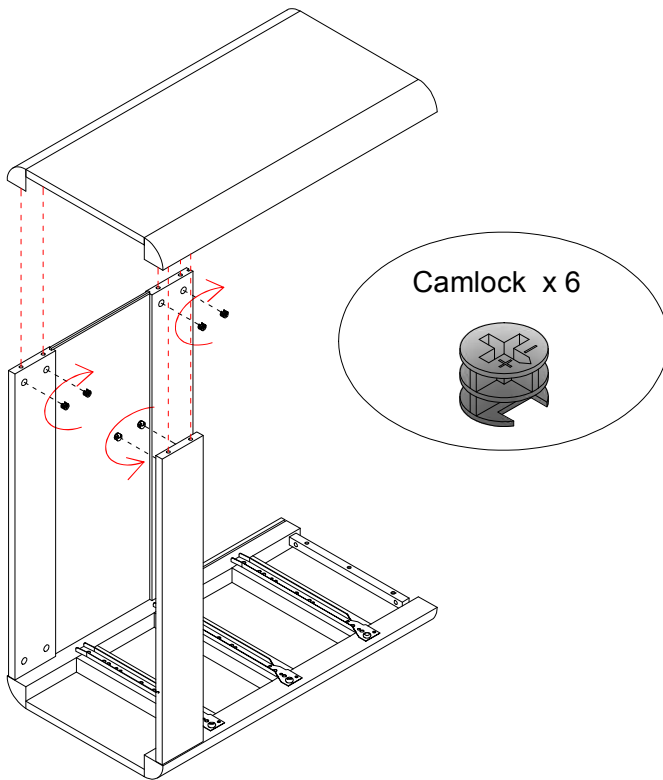

5 Insert back panel sliding into grooves on two side panels.

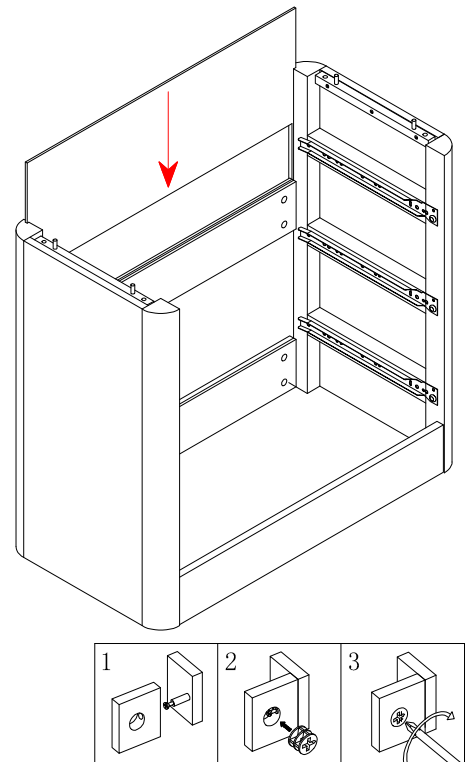

6 Place top board onto chest frame secure with M6 x 35mm bolts.

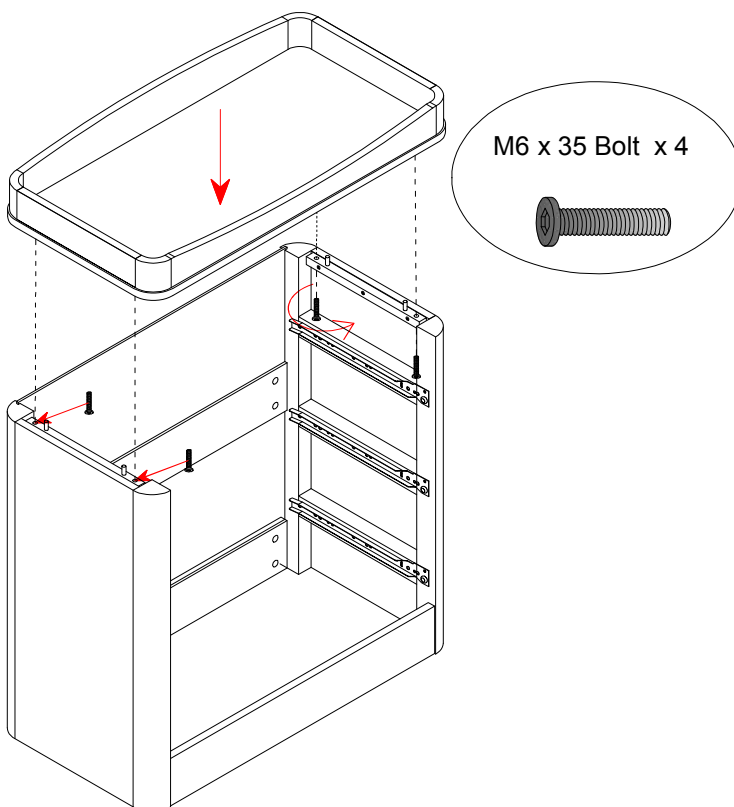

7 Tighten all bolts and screws by allen key but do not over tighten.

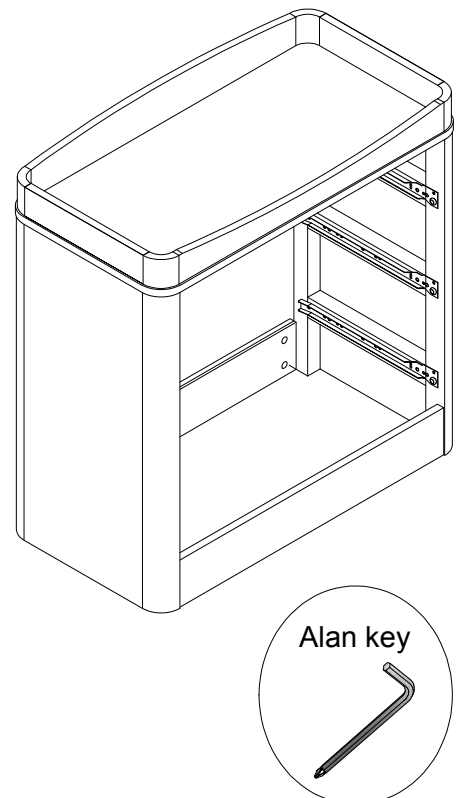

Locking pin x 4

8 Fit locking pins to drawer side panels.

Fit side panels to drawer back panel secure with camlocks.

Insert base sliding into grooves on side panels.

Locking pin x 4

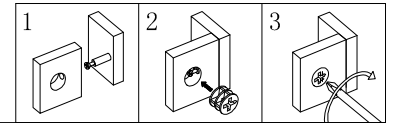
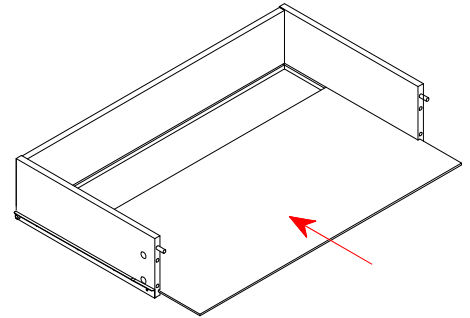
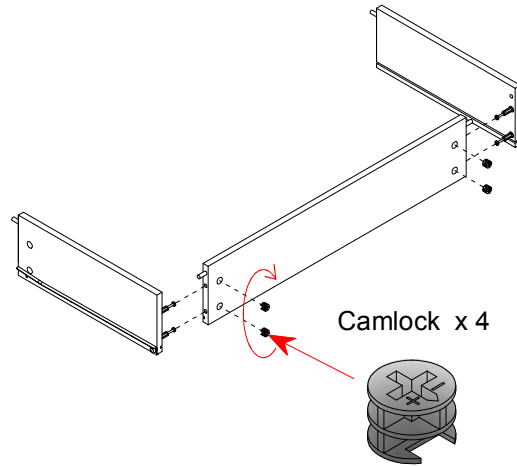
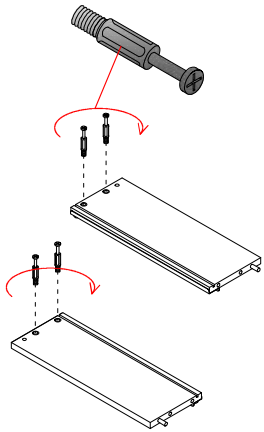

9 Fit locking pins into front drawer panels.

Align the drawer front panel secure with locking pins and camlocks.

Locking pin x 4

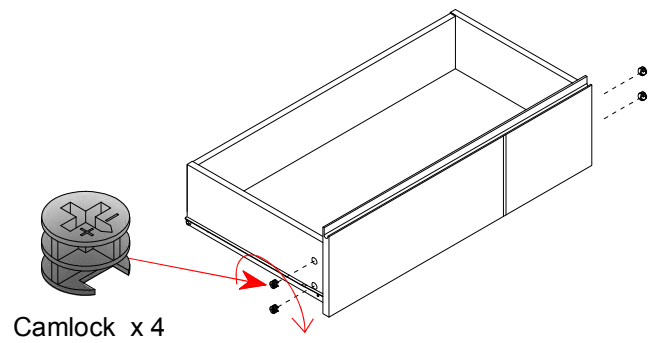
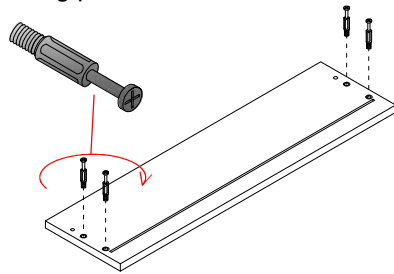

10 Insert drawers, the chest is completed.

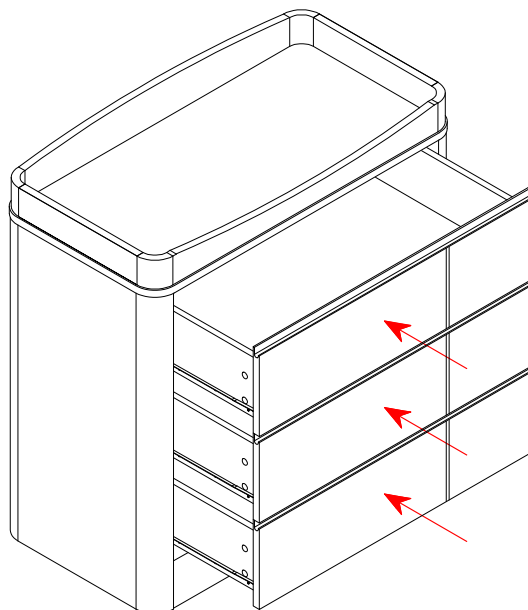

Instruction for Wall Strap installation

Hardware List

A.2 x Self tapping screw



B.1xWall strap

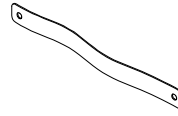

Step 1- Screw Wall Strap to back of the chest with Self tapping screw(Supplied)

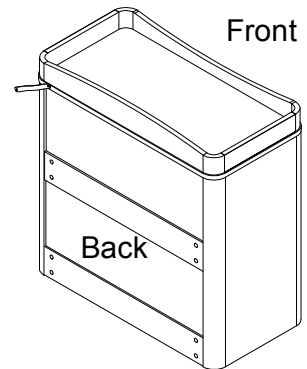
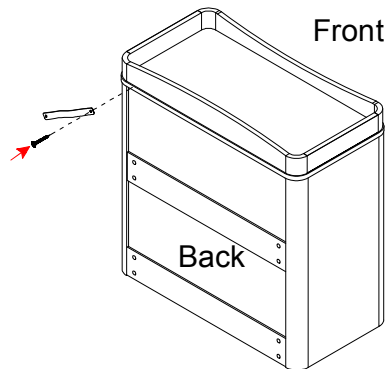
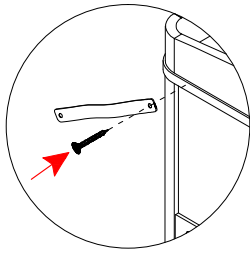

Step 2- Position the strap 100mm the left of its intended final position in order to give you room the screw the wall strap into the wall.
Please note:The wall fixing is not supplied,Please seek advice from your local hardware supplier to ensure you purchase the correct wall fixing.

Step 3- Ensure the wall strap is fixed into the wall securely.

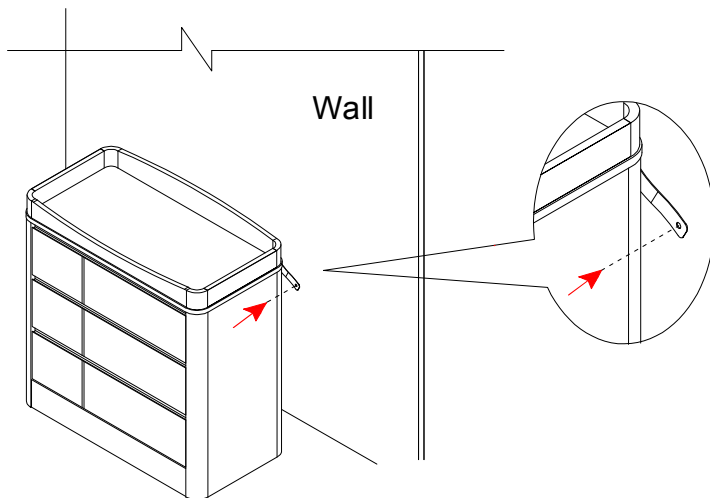

Step 2

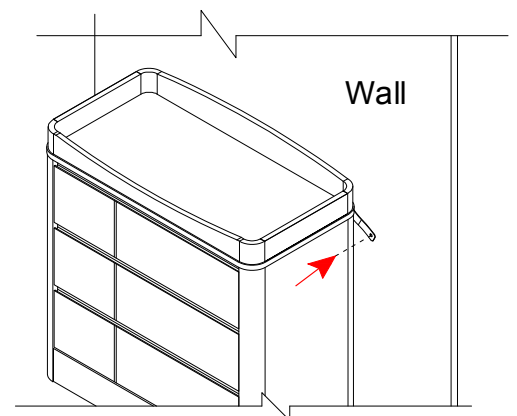

Step 3

Step 4- Once you have completed step 3 then reposition the chest in its intended position(Two people maybe required for this step):

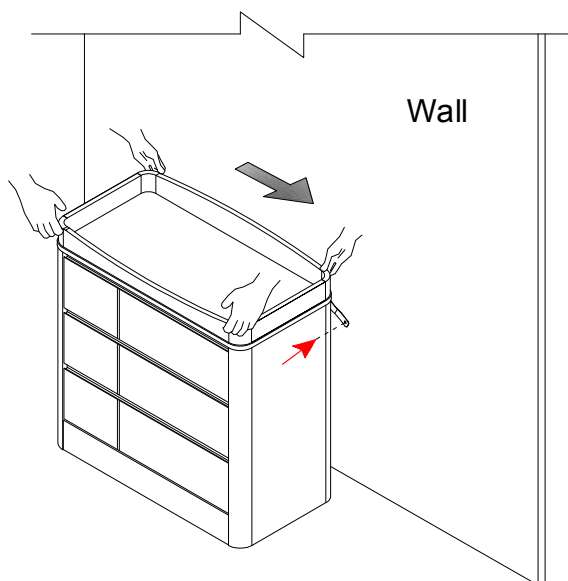

Step 5- The stallation of your wall strap is now completed

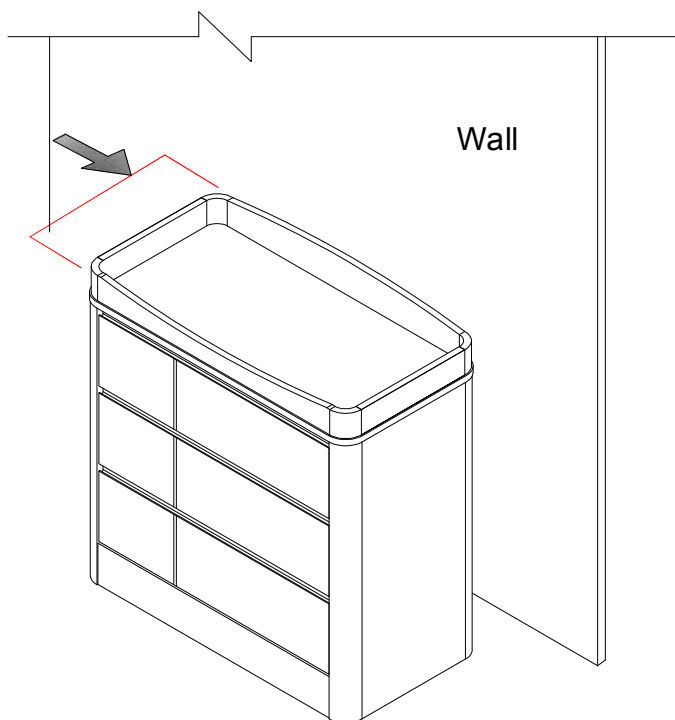

**Save the instructions for future reference.
Assembly of this furniture is best undertaken by two people.**



Packaging and instructions
printed on recycled materials



SJC Brands Pty Ltd ABN. 58 106 988 578 Email:customer.service@sjcbrands.com.au
4-6 Merryvale Rd, Minto, NSW 2566 p.o. box 5878 MINTO DC, NSW 2566
t. 02 9603 5000 f. 02 9603 7000 w. www.tasmaneco.com.au

Our goods come with guarantees that cannot be excluded under the Australian Consumer Law. You are entitled to a replacement or refund for a major failure and for compensation for any other reasonably foreseeable loss or damage. You are also entitled to have the goods repaired or replaced if the goods fail to be of acceptable quality and the failure does not amount to a major failure. The guarantee described below is in addition to the guarantee provided by law.

2 YEAR MATERIALS AND WORKMANSHIP GUARANTEE

If within 2 years of the date of purchase of this product, there is found any defect in materials or workmanship of this product, SJC Brands Pty Ltd will replace the product free of charge, subject to the condition below:

The replacement product will be identical to the originally purchase product wherever possible, though in situations where the identical model is discontinued or out of stock, then SJC Brands Pty Ltd will replace the product with a model that is functionally equivalent

This Guarantee is made to the purchaser and/or original owner only. For purposes of this Guarantee, the original owner is considered to be the person who first makes use of the product.

Note: In situations where a person purchases this product for the purpose of gifting to another, the recipient is considered to be the original owner.

CONDITIONS:

The 2 Year Material and Workmanship Guarantee will be void and nullified in circumstances where:

- 1.The item is improperly assembled or adjusted and or not assembled strictly in accordance with the written instructions provided by the seller in the box containing the item.
- 2.There is damage to the product and that damage is deemed by SJC Brands Pty Ltd to be caused by incorrect assembly, misuse or by use or storage outside of the physical or environmental specifications of the product.
- 3.There are modifications to the product or to parts of the product that were not authorized in writing by SJC Brands Pty Ltd.
- 4.The item is transferred, gifted or disposed of by the original owner to another.

WARRANTY CLAIM PROCEDURE:

For warranty claims, please email us via our claims section on our website www.tasmaneco.com.au or visit the store where the product was purchased.

The product must be returned to SJC Brands Pty Ltd or to the place of purchase with proof of purchase, including date and purchase price.

SJC Brands Pty Ltd ABN. 58 106 988 578

4-6 Merryvale Rd , Minto , NSW 2566

PH: 02 9603 5000 FAX: 02 9603 7000

[w. www.tasmaneco.com.au](http://www.tasmaneco.com.au)

Email: customer.service@sjcbrands.com.au